

Pre-Cleaning Separator GCS

Genç Degirmen
MILLING MACHINERY

Excellent Milling Properties...

WORKING PRINCIPLES

The Pre-Cleaning Separator separates the grain from coarse and fine impurities by screening. In addition, it grades a wide variety of products by size.

Using a screen separation system, the Pre-Cleaning Separator separates the grain from coarse impurities such as oversize grains, strings, straw, wood, stones and pebbles, or clods of earth plus fine impurities such as sand or broken grains.



Product Data Sheet

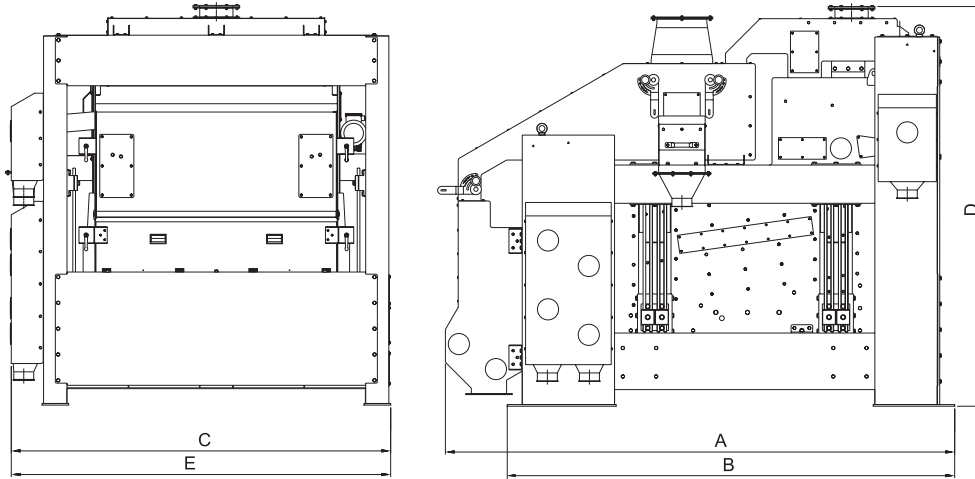

Type	Technical Features		Power (kw)	Sieve Dimensions (mm)	Dimensions (mm)					Weight (kg)
	Capacity (t/h)			Width x Length	A	B	C	D	E	
	*Pre-Cleaning	*Cleaning								
GCS 400	50	50	0.75	1781 x 3062	2690	3062	1596	2605	1781	2455
			2.2							
GCS 600	80	80	0.75	2281 x 3062	2690	3062	2096	2605	2281	3050
			2.2							